

N.B. Per la pignatura delle staffe ripetere le seguenti prescrizioni:
N.B. Le dimensioni devono essere verificate all'atto esecutivo.
N.B. Le dimensioni sono espresse in millimetri.
N.B. Le dimensioni sono espresse in metri.

TABELLA MATERIALI

CLS.	CLASSE	TIPO	TIPO	TIPO	TIPO
MARCO DI FONDAZIONE	C12/15	Ø16	S4	<25mm	X10
FONDAZIONI	C12/15	Ø16	S4	<25mm	X10
PARETE C.A. E RAMPE	C12/15	Ø16	S4	<16mm	X11
PILASTRI	C12/15	Ø16	S4	<16mm	X11
SETTI	C12/15	Ø16	S4	<16mm	X11
SOLAI	C12/15	Ø16	S4	<16mm	X11
TRAVI E SOLLETTE	C12/15	Ø16	S4	<16mm	X11

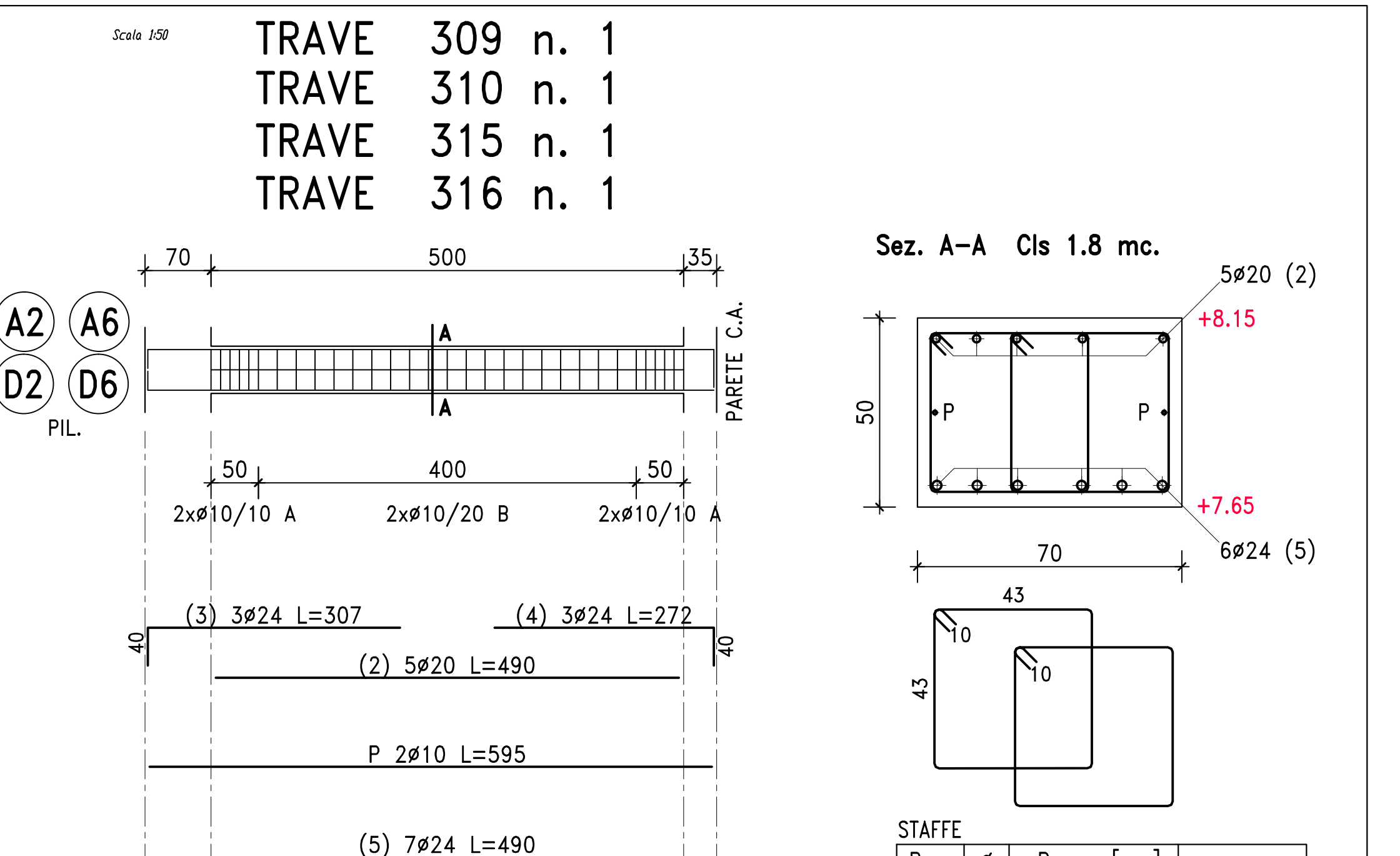
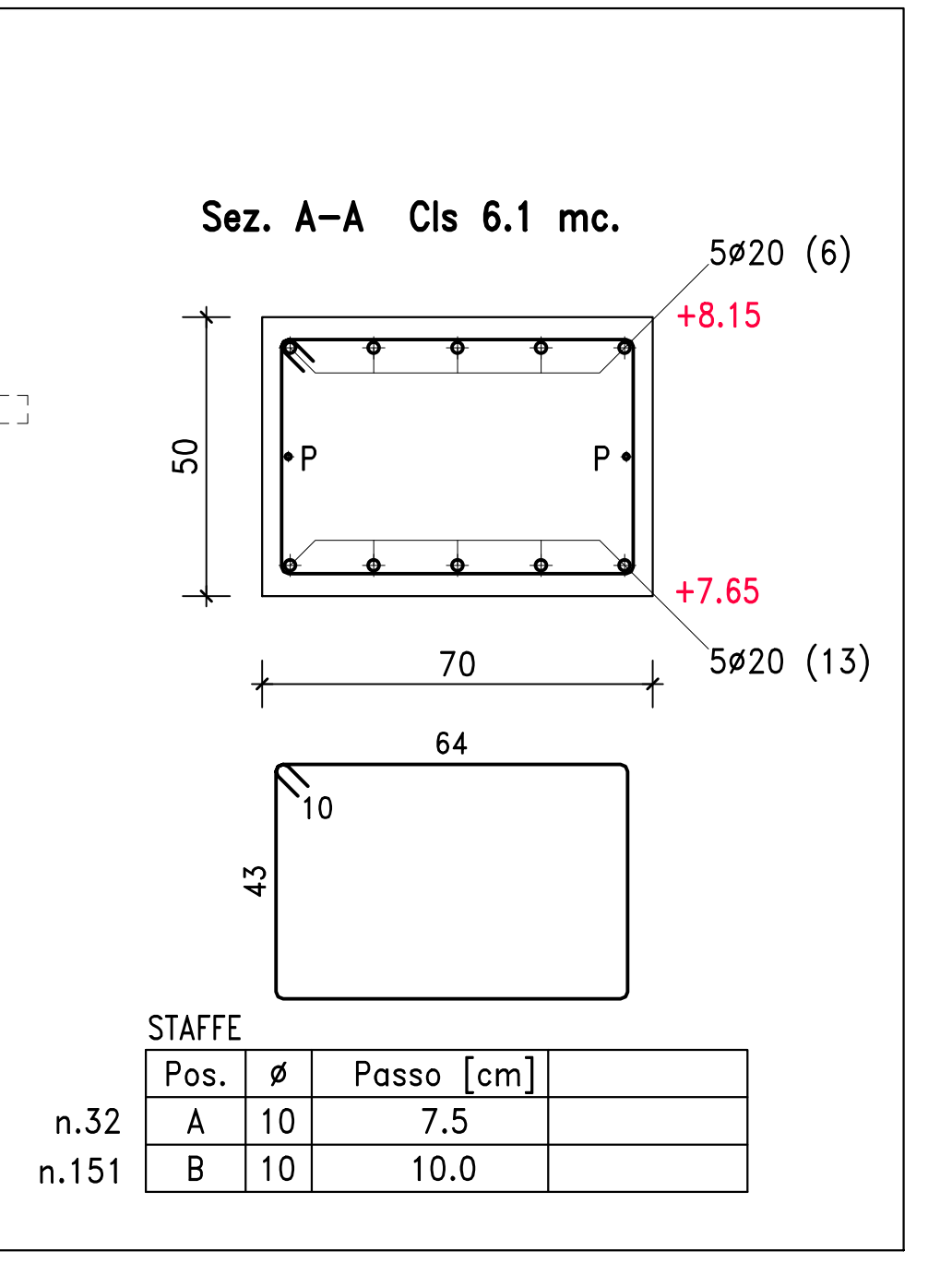
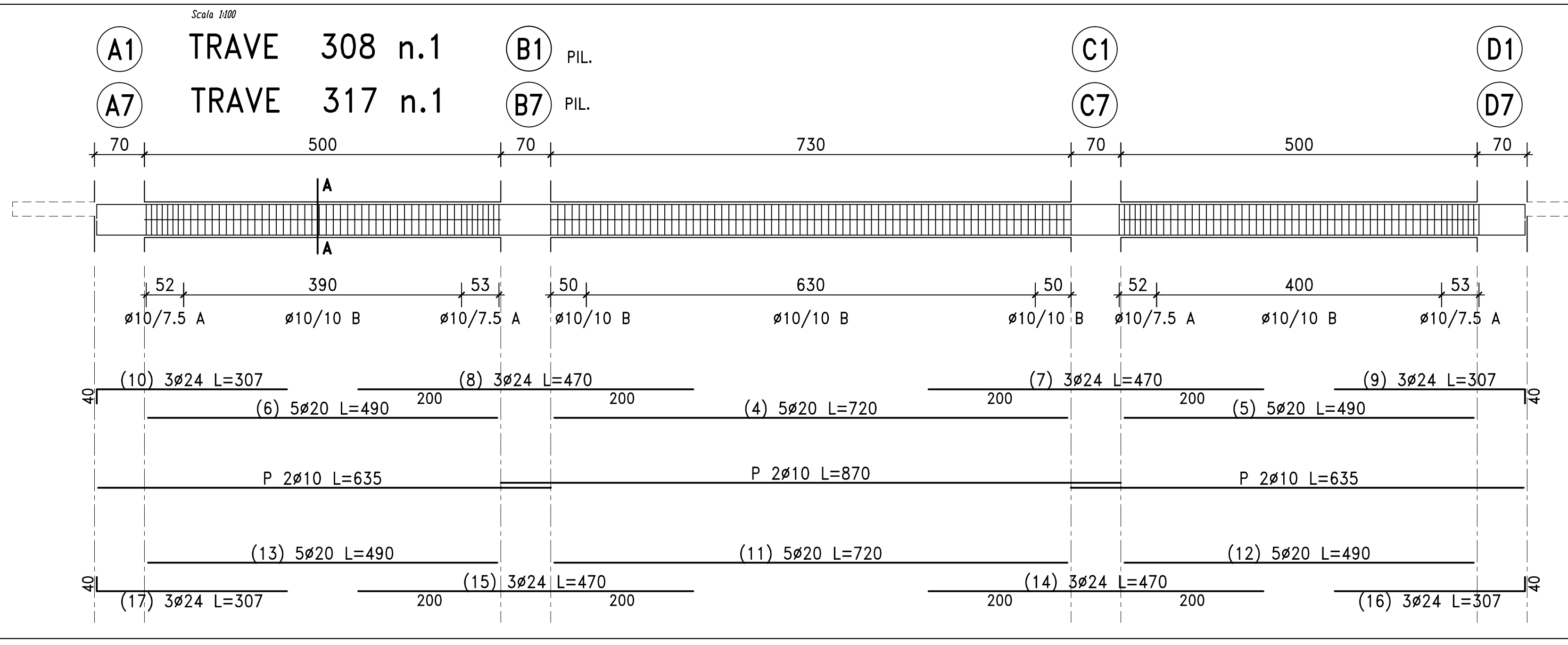
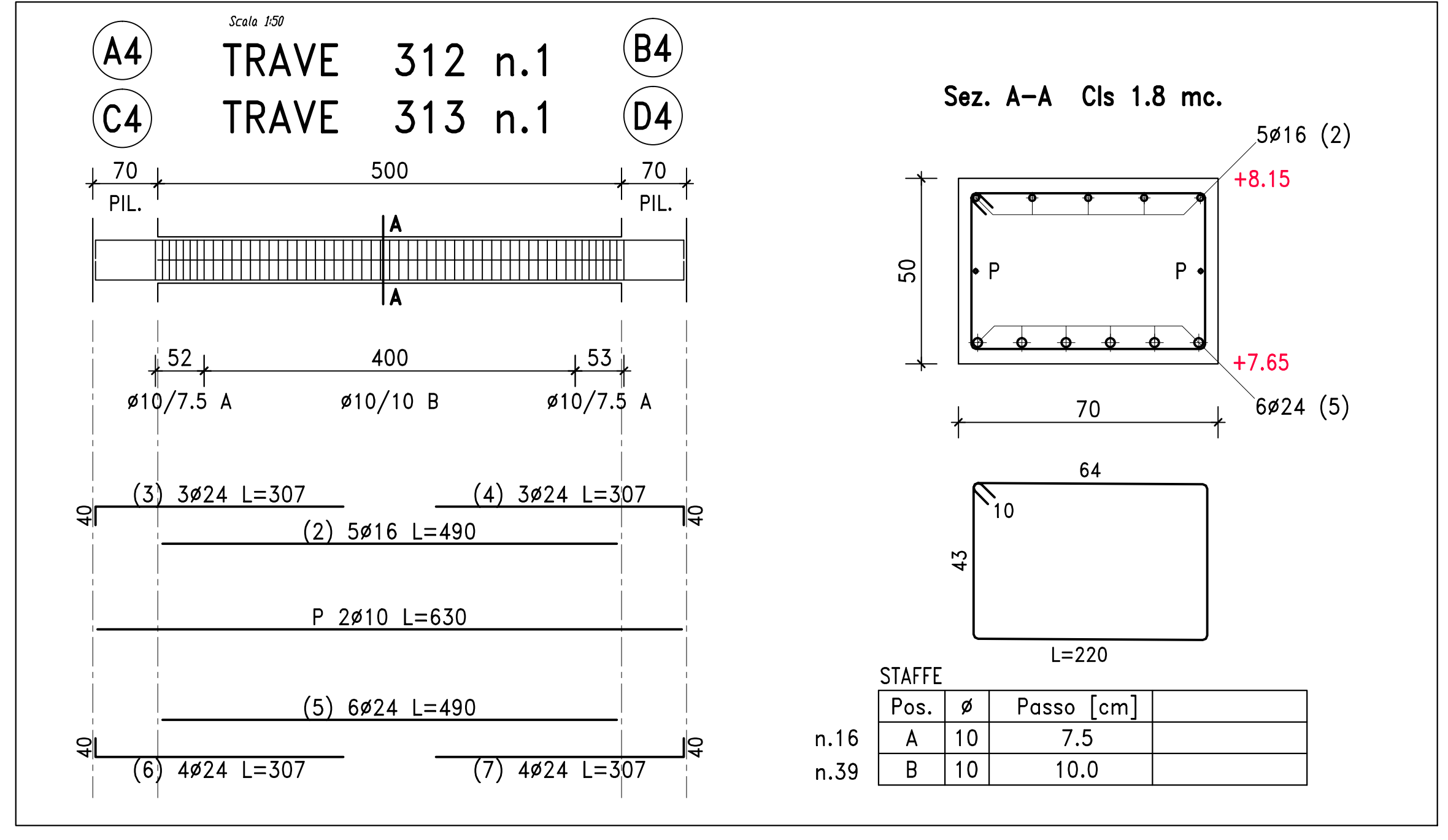

ACCIAIO CARPENTERIA S 275JR ZINCATO A CALDO
ACCIAIO BARRE FILETATE CLASSE B.3 ZINCATO
ACCIAIO VITI PER BOLLONI CLASSE 8.8 ZINCATO
CAVITÀ CLASSE 2 ZINCATO

STOFFE

TIPO	TIPO	TIPO	TIPO
Ø 10/11	Ø 12	Ø 14	Ø 16
Ø 18	Ø 20	Ø 22	Ø 25
Ø 28	Ø 32	Ø 36	Ø 40
Ø 45	Ø 50	Ø 56	Ø 63
Ø 70	Ø 78	Ø 86	Ø 95
Ø 108	Ø 120	Ø 132	Ø 140
Ø 150	Ø 160	Ø 170	Ø 180
Ø 200	Ø 220	Ø 240	Ø 260
Ø 280	Ø 300	Ø 320	Ø 350
Ø 400	Ø 450	Ø 500	Ø 550
Ø 600	Ø 650	Ø 700	Ø 750
Ø 800	Ø 900	Ø 1000	Ø 1100
Ø 1200	Ø 1300	Ø 1400	Ø 1500

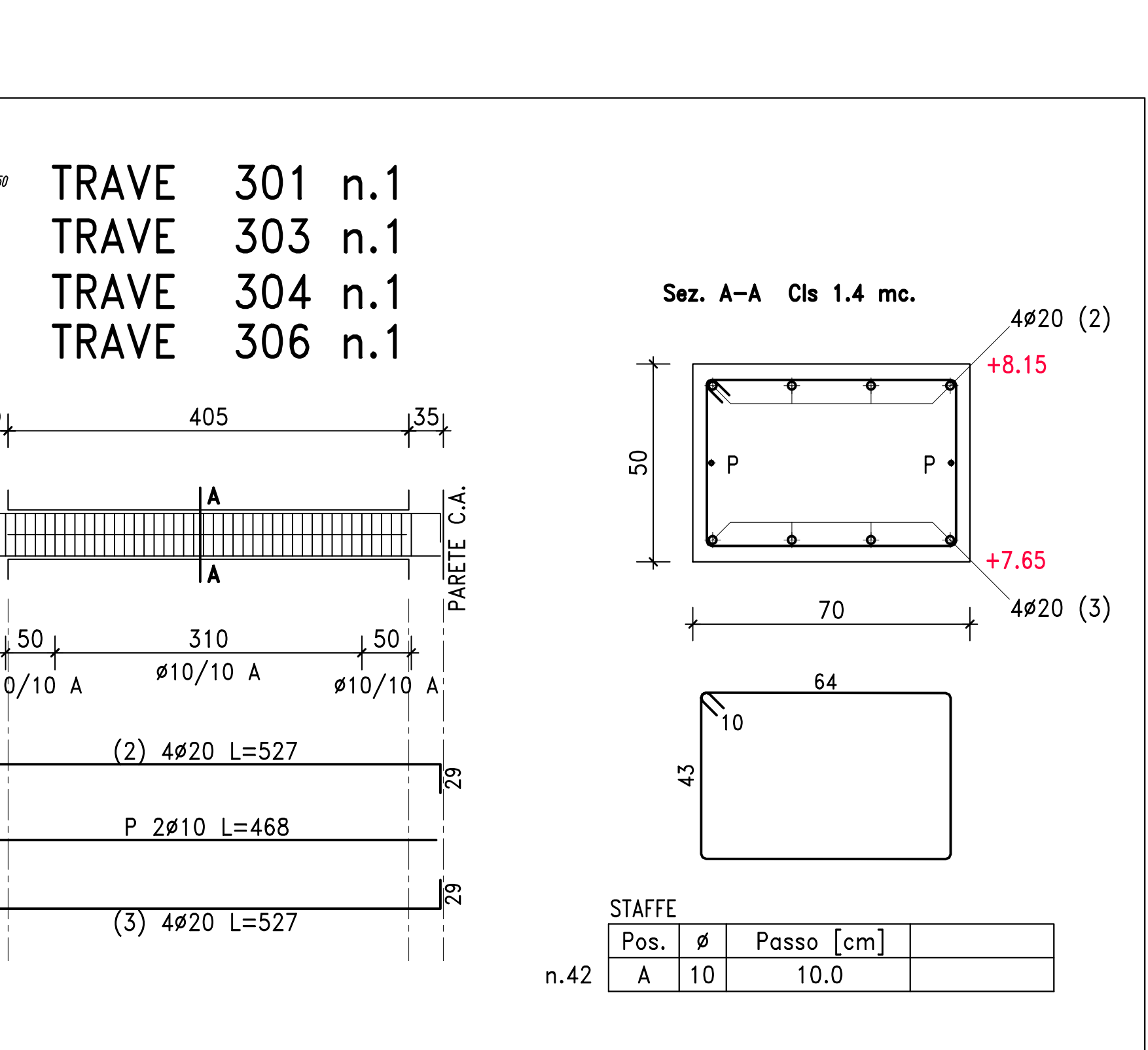
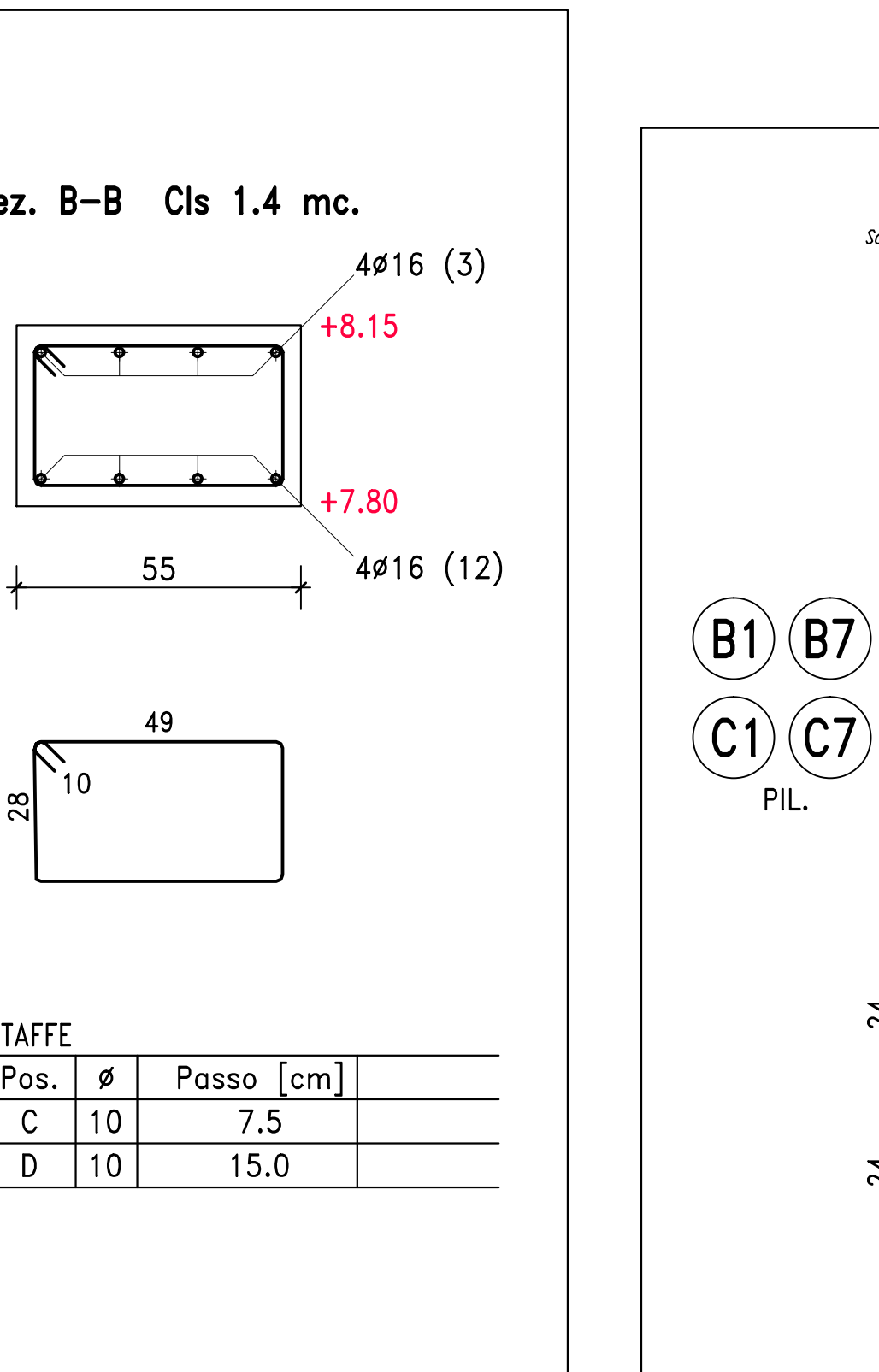
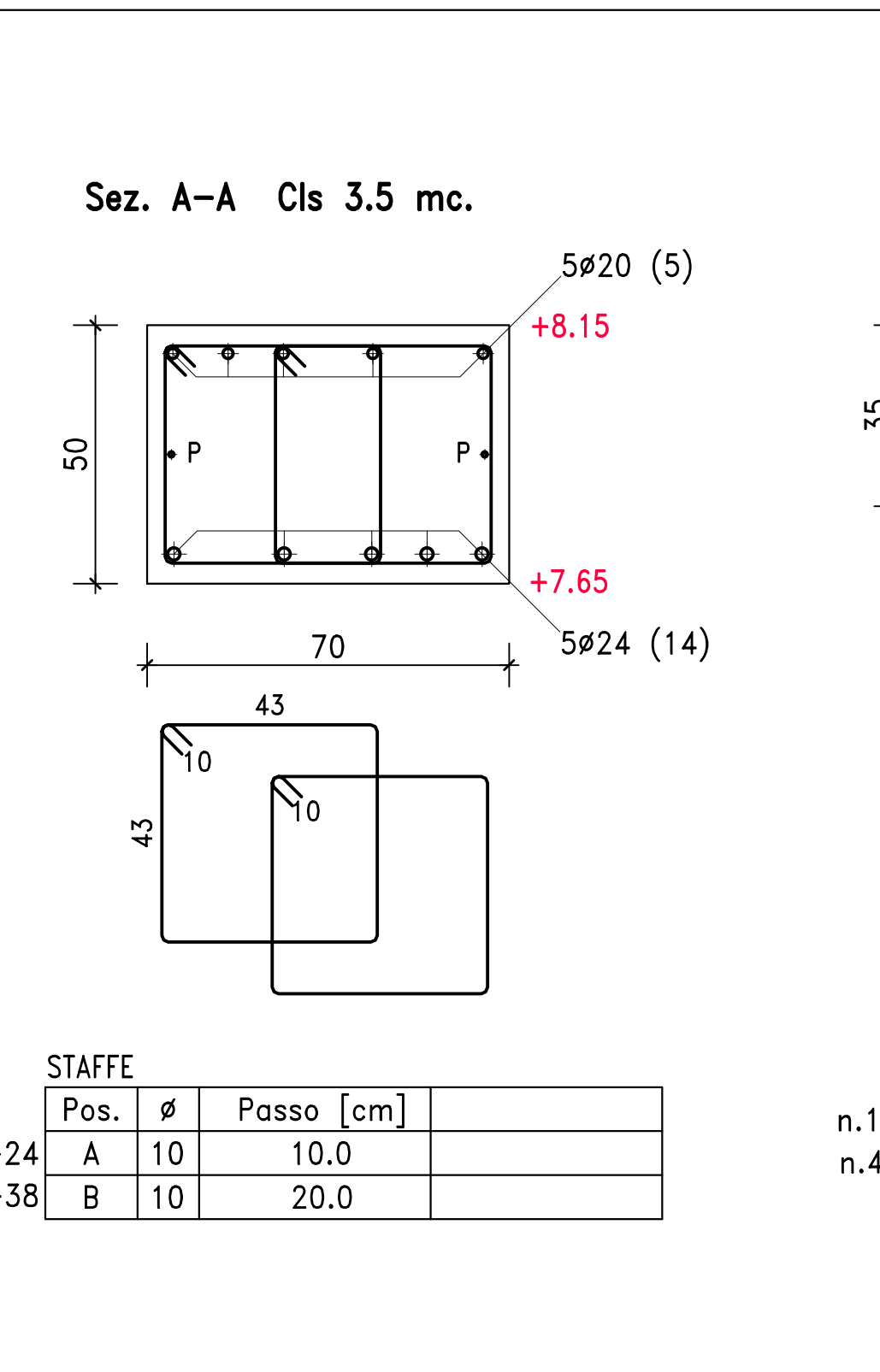
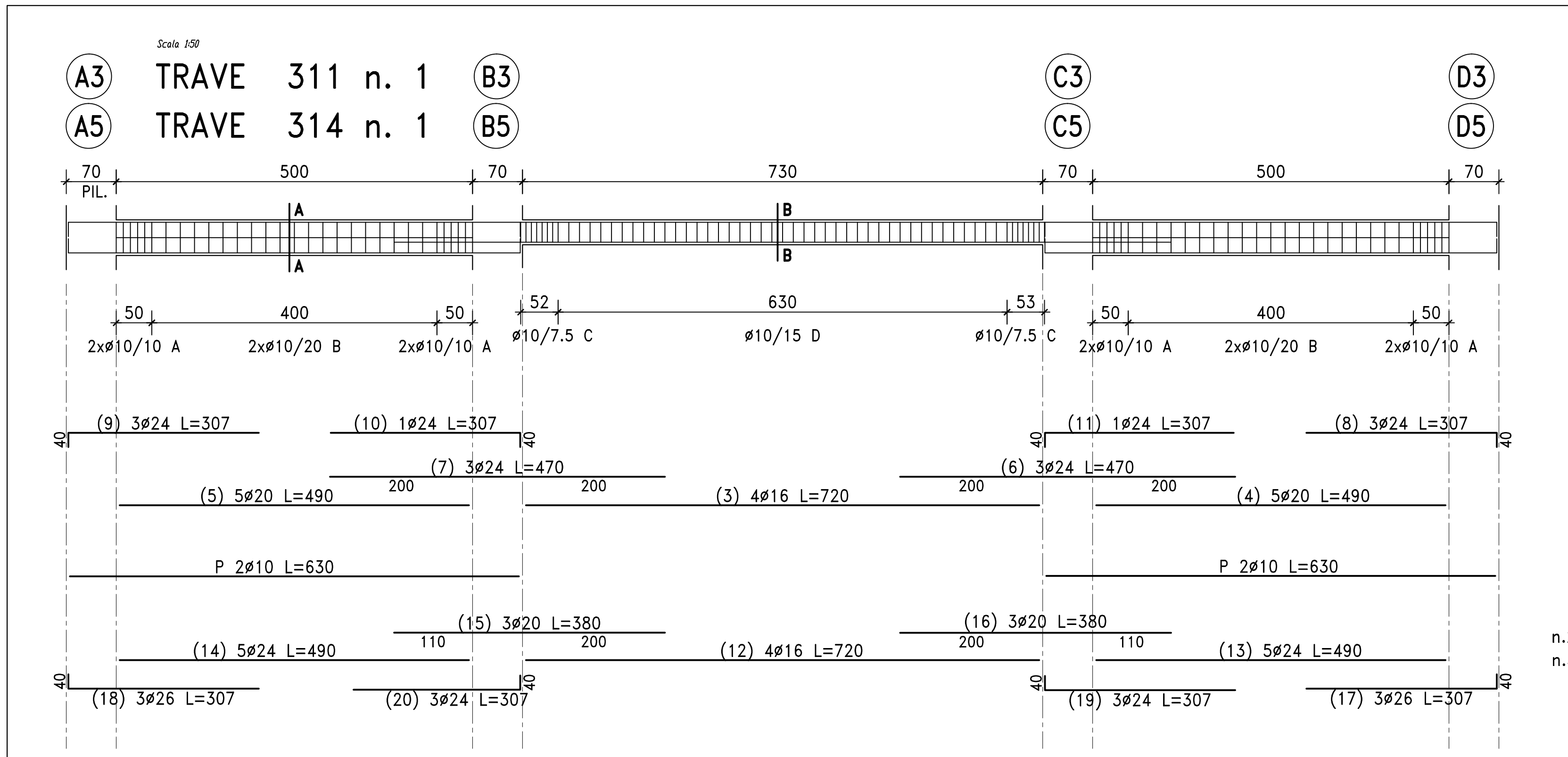
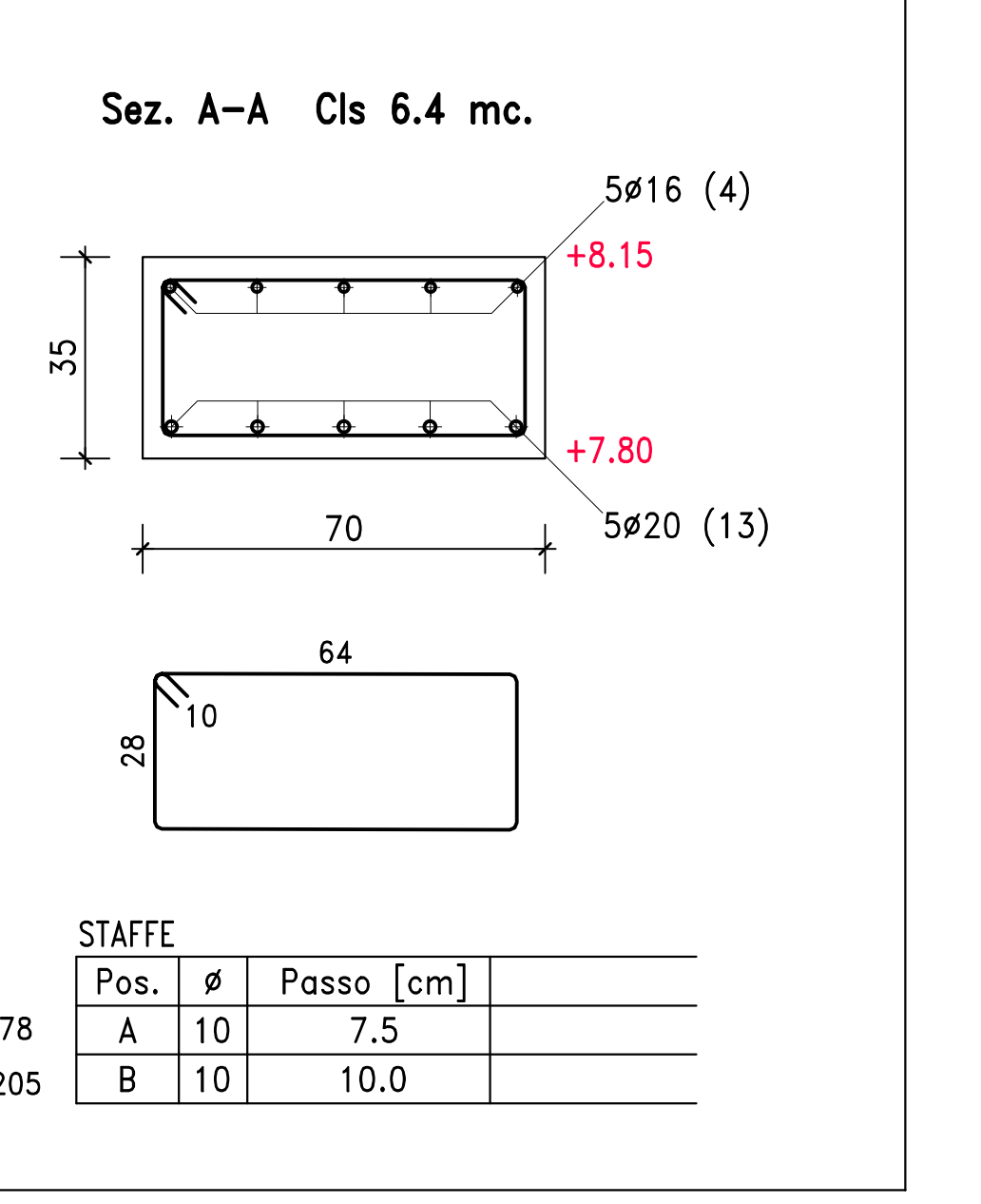
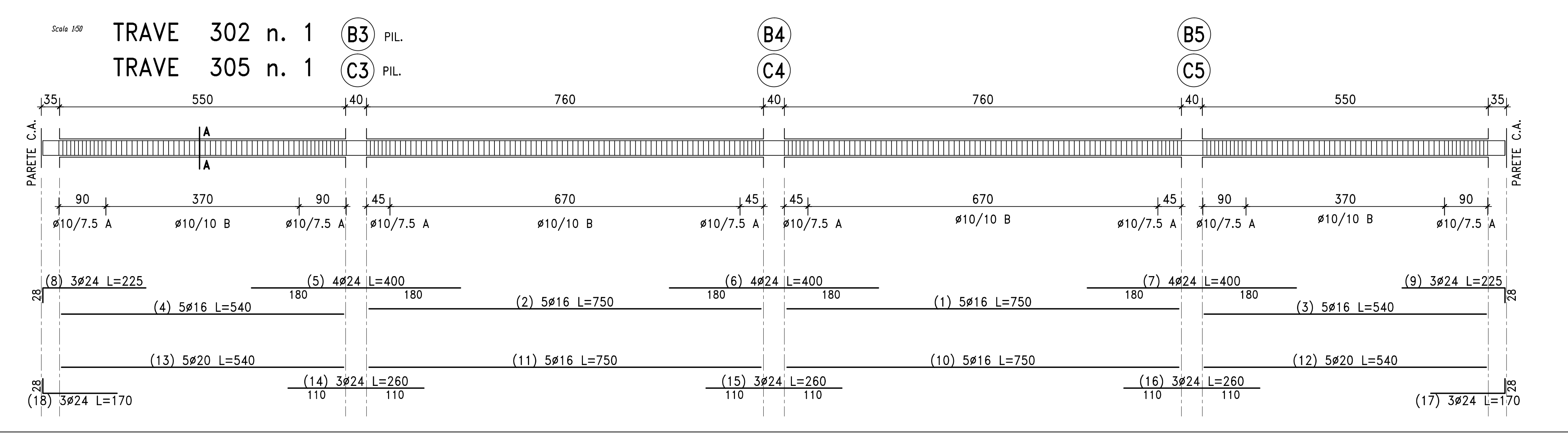

AGENZIA DEL DEMANIO
 Direzione Regionale Calabria

PROGETTO ESECUTIVO

PROPRIETÀ: Agenzia del Demanio Direzione Regionale Calabria

PROGETTAZIONE: Arch. Roberto Longo, Arch. Marina Bucchi, Arch. Laura Macchi

PROGETTAZIONE STRUTTURALE: Ing. Mauro Petri

PROGETTAZIONE IMPIANTISTICA: Ing. Lino Polastri

PROGETTAZIONE SCENOGRAFICA: Dott. G. Alberto Capora

TEAM DI PROGETTAZIONE: Arch. Roberto Longo, Arch. Marina Bucchi, Arch. Laura Macchi

OGGETTO: PROGETTO STRUTTURE Armature Travi 3° Solajo

TAV. N.: PE-ST-09_1

DATA: 31.10.2018

SCALA: 1:50